

**UNIVERSITY COLLEGE TATI (UC TATI)****FINAL EXAMINATION QUESTION BOOKLET**

COURSE CODE	:	DMT 3042
COURSE	:	INDUSTRIAL ROBOTICS
SEMESTER / SESSION	:	01 - 2023/2024
DURATION	:	3 HOURS

Instructions:

1. This booklet contains **5** questions. Answer **ALL**.
2. All answers should be written in the answer booklet.
3. Write legibly and draw sketches wherever required.
4. If in doubt, raise your hand and ask the invigilator.

DO NOT OPEN THIS BOOKLET UNTIL YOU ARE TOLD TO DO SO

THIS BOOKLET CONTAINS 5 PRINTED PAGES INCLUDING COVER PAGE

QUESTION 1

- a) Robots are considered a key element in many fields and applications, such as engineering, manufacturing, medicine, entertainment, education, and more.
- Define an industrial robot term referring to Robotic Industries Association (RIA). (4 marks)
 - List THREE (3) laws of robotics. (3 marks)
- b) Robotics terminology consists of several elements or components. (10 marks)
Explain the FIVE (5) elements and their purpose.
- c) A special spraying robot has been designed, as shown in Figure 1.

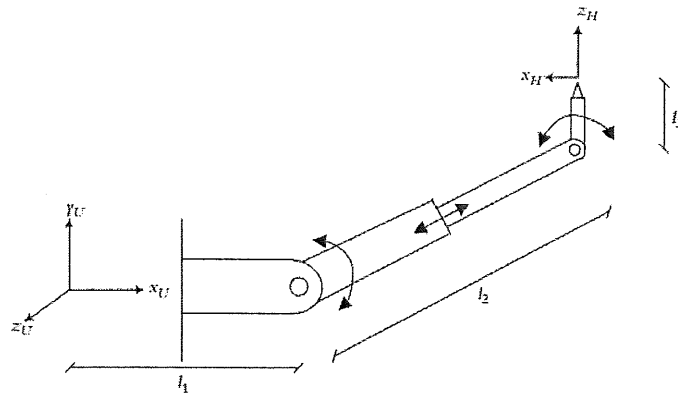

Figure 1

- Determine the degree of freedom of this robot. (1 mark)
- Name the joints that contribute to the degree of freedom of this robot. (2 marks)

QUESTION 2

- a) End effectors are devices attached to the wrist of a manipulator. List SIX (6) end effectors commonly found in the industry. (6 marks)
- b) Illustrates FOUR (4) relationships between accuracy and repeatability for industrial robots. (8 marks)
- c) Explain the THREE (3) types of drive power sources of industrial robots. (6 marks)

QUESTION 3

- a) Determine FOUR (4) of the most common major production applications in the robotics industry. (4 marks)
- b) One method of classifying a robot is by the geometric configuration of its work envelope. List FOUR (4) major configurations of industrial robot manipulators. (4 marks)
- c) Describe the FOUR (4) subsystems of the robot controller. (8 marks)
- d) Various ways exist to classify industrial robots based on their motion control methods. List FOUR (4) industrial robot categories. (4 marks)

QUESTION 4

- a) A robot uses several coordinate systems, each suitable for specific types of jogging or programming.
- i) Explain the base coordinate system (BCS). (2 marks)
 - ii) Explain the tool coordinate system (TCS). (2 marks)
 - iii) State the differences in the Jogging operation in BCS and TCS. (4 marks)
- b) One of the important characteristics of robotic arm is their ability to be programmed to perform tasks automatically.
- i) List the TWO (2) basic types of programming methods which are consistent with current industrial practice. (2 marks)
 - ii) Explain the powered lead-through programming method of the robotic arm. (2 marks)
 - iii) Explain the manual lead-through/walk-through programming method of the robotic arm. (2 marks)
- c) Based on the robot ABB teach pendant programming, explain the motion instructions:
- i) MoveJ instruction (2 marks)
 - ii) MoveL instruction (2 marks)
- d) Write instructions to move the ABB robot with the tool, *Tool0* non-linearly to the robot position, *Target1* with velocity data *v1000*, and zone data *z50*. (2 marks)

QUESTION 5

- a) Safeguarding devices are essential to ensuring the safety of personnel (3 marks) working with or around machinery and equipment. List THREE (3) of these devices.
- b) Robot accidents do not occur under normal operating conditions. (3 marks) Describe the THREE (3) occasions of the robot accidents.
- c) Define Computer Integrated Manufacturing (CIM) term referring to the (3 marks) Computer and Automated Systems Association (CASA) and Society of Manufacturing Engineers (SME).
- d) Computer Integrated Manufacturing (CIM) offers several benefits to (4 marks) manufacturing organizations. Give FOUR (4) benefits of CIM.
- e) Define a Flexible Manufacturing System (FMS). (3 marks)
- f) A Flexible Manufacturing System (FMS) consists of several (4 marks) interconnected components that create a flexible and efficient manufacturing environment. List FOUR (4) key components typically found in an FMS.

-----End of Questions-----

